

Profile door installation instructions

1. General

These instructions are designed for a specialist who is competent in the field of installation of profile doors and non-load bearing profile walls (hereinafter the product). The types and specifications of the product are provided in Table 1. Before installation, please read the instructions and bring all the required materials and tools to the installation site. Determine the final finishing of the surrounding structures and the position of the product in the structure. Determine the locations of any potential communications in the structure to prevent driving the fixing elements of the product into any electric or weak-current wires, underfloor heating pipes, etc. Always place the product on a 'soft' surface in the installation site to prevent damaging the finishing of the product. Restrict the access of unauthorised individuals to the installation site for the duration of the installation works. Wear protective gloves and personal protective equipment that must be worn when working with the tools used during the installation works.

TABLE 1 Profile door types

Door type tüüp	E15	E20	E30	E45	E60	E90	E120	El ₂ -15	El ₂ -20	El ₂ -30	El ₂ -45	El ₂ -60	El ₂ -90	El ₂ -120
K-1	-	-	-	-	-	-	-	-	-	-	-	-	-	-
K-2	-	-	-	-	-	-	-	-	-	-	-	-	-	-
K-3	-	-	-	-	-	-	-	-	-	-	-	-	-	-
TK-01	X	X	X	X	X	-	-	-	-	-	-	-	-	-
TK-03	-	X	X	-	X	-	-	X	X	X	X	X	-	-
TK-04	-	X	X	-	X	-	-	X	X	X	-	-	-	-
TK-05	X	X	X	-	-	-	-	X	X	X	-	-	-	-
TK-06	X	X	X	X	X	-	-	X	X	X	X	X	-	-
TPS-120	-	X	X	-	X	X	X	X	X	X	X	X	X	X

2. Product

2.1. The set

The set consists of the door sheet, frame, striking plate, caps for covering the installation holes, and seals. Depending on the requirements and the specific order, the door set may also include a window, ventilation grid, mail hatch, lock frame, lock core with a cover, door knob, fix, panic exit lock, door closer, door viewer, cable bushing, magnet, automatic door sealing system, rubber seals, linear strip brush seals, and design elements

2.2. Protection

Marking: 06J36v2	
Compiler: Jürgen Treial	
Approved: Kaider Puniste	
Valid from: 01.04.2024	

The door sheet is covered with a film in the factory. The film is not designed for protecting the product from damages or stains during construction works. In order to protect the door sheets from damages or staining, it is advisable to cover them with construction cardboard or thicker plastic sheets. **Never tape over the seals on the frame and on the door sheet** when covering the door and working on the structures surrounding the door, as the seal may break or become loose as a result of removing the tape. Our warranty does not extend to seals that have been damaged in this manner.

3. The materials and tools required for installation

3.1. Frame mounting wedges

Mounting wedges help to place the door in the proper position but are not required or compulsory tools for the installation of the door. When installing a TU product, the mounting wedges must be made of a non-combustible material, such as promatech, steel, cement fibreboard, dry wall, etc. Pieces of dry wall are not suitable for using as mounting wedges under the door sill.

3.2. Fasteners and isolation materials

Suitable isolation materials for doors with fire resistance class are shown in table 2. Isolation material for doors without a fire resistance class are freely selectable according to the environmental conditions. Door frame must be fixed with fasteners that are suitable for the wall type. The fasteners minimum dimensions are shown in table 2.

Marking: 06J36v2	
Compiler: Jörgen Treial	
Approved: Kaider Puniste	
Valid from: 01.04.2024	

TABEL 2 Fasteners and isolation materials

	K-1	K-2	K-3	TK-01		TK-03	TK-04		TK-05		TK-06		TPS-120
				Fire	Smoke		rigid	Non rigid	fire	smoke	fire	smoke	
Isolation materials / maximum mounting gap													
Rockwool with density ≥ 28 kg/m ³ (e.g. Paroc Ultra)	50mm	50mm	50mm	30mm	≤ 20 mm	30mm	≤ 30 mm	20mm	30mm	≤ 20 mm	30mm	≤ 20 mm	Not allowed
Rockwool with density ≥ 39 kg/m ³	-	-	-	-	-	-	-	-	-	-	-	-	40mm
Fire rated gunfoam (e.g. PENOSIL Fire Rated Gunfoam B1 187 or Soudal Soudafoam FR)	50mm	50mm	50mm	30mm	≤ 15 mm	Not allowed	20mm	30mm	30mm	Not allowed	20mm	Not allowed	Not allowed
Gunfoam not firerated	50mm	50mm	50mm	Not allowed		Not allowed	Not allowed		Not allowed		Not allowed		Not allowed
Minimum dimensions for fasteners													
Concrete screw (\varnothing min, length)	7,5x72*	7,5x72*	7,5x72*	7,5x72*		7,5x72*	7,5x72*		7,5x72*		7,5x72*		7,5x100*
Lightweight block screw (\varnothing min, length)	8x90	8x90	8x90	8x90		8x90	8x90		8x90		8x90		-
Self-drilling metal screw (\varnothing min, length)	4,8x32	4,8x32	4,8x32	4,8x32		4,8x40	4,8x40		4,8x40		6,3x50		-
Wood screw (\varnothing xmin, length)	6x80 7,2x72	6x80 7,2x72	6x80 7,2x72	6x80 7,2x72		6x80 7,2x72	6x80 7,2x72		6x80 7,2x72		6x80 7,2x72		-

* The penetration of the concrete screw into the concrete substructure is at least 50 mm

* Rigid mounting means the door is mounted in a bearing wall made out of concrete, block, etc.

* Non rigid mounting means the door is mounted in a non bearing wall made of sandwich panels, light wood structure, etc.

The diameter of the heads of the fixing elements can be at most 13 mm due to the diameter of the installation holes in the frame.

Marking: 06J03v6	 TO WELCOME AND PROTECT
Compiler: Jaak Järvpõld	
Approved: Kaider Puniste	
Valid from: 01.04.2024	

4. Requirements for the openings for installation of the products

- 4.1. The sides of the opening must at least meet the requirements for class 2 of the RYL 2000/2010 standard for structures. The edges must be free of any residual grout and other foreign bodies to ensure the best possible installation. The surface under the door sill must be as level as possible, straight, and of a load-bearing material (concrete, brick, wood, steel, etc.). Otherwise, the maximum permitted deflection of the sill cannot be ensured (+/- 2 mm).
- 4.2. In the case of a light steel frame wall, an at least 50 mm wooden reinforcement beam or a reinforcement profile must be used in the frame of the wall in the entire width of the frame.
- 4.3. When installing the product in a sandwich wall, the opening must be prepared based on the instructions of the manufacturer of the panels or based on the building design documentation. The products of Doordec OÜ may be installed in a steel box of the thickness of at least 1.0 mm.

If the conditions specified in points 4.1–4.3 are not met, the possibilities for installing the product and the potentially required additional work must be specified separately in each specific case and the contracting entity should be asked to confirm the additional installation work. The manufacturer cannot guarantee the proper functioning of a product which has been installed in an improper opening and the warranty of the product will become invalid.

5. Installation of the product

5.1. General instructions

- Fixing holes have been prepared by the manufacturer, diagram 1. On the product K-3, the selection of mounting locations must be based on diagram 1 and diagram 2

Diagram 1. Fixing hole placement

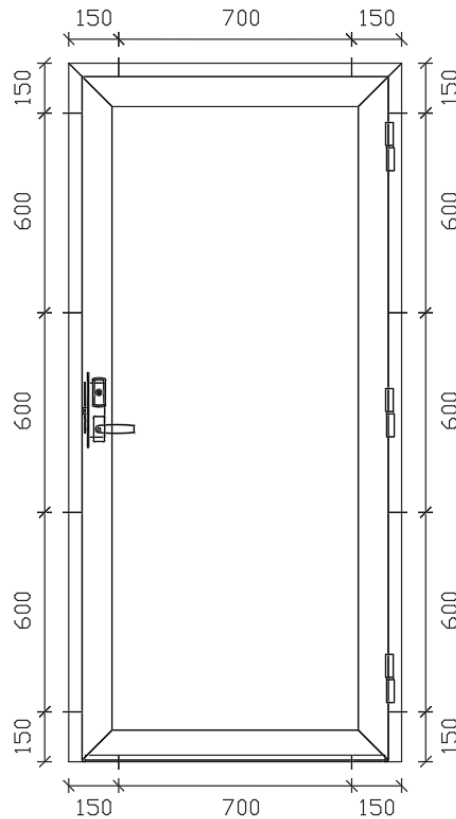
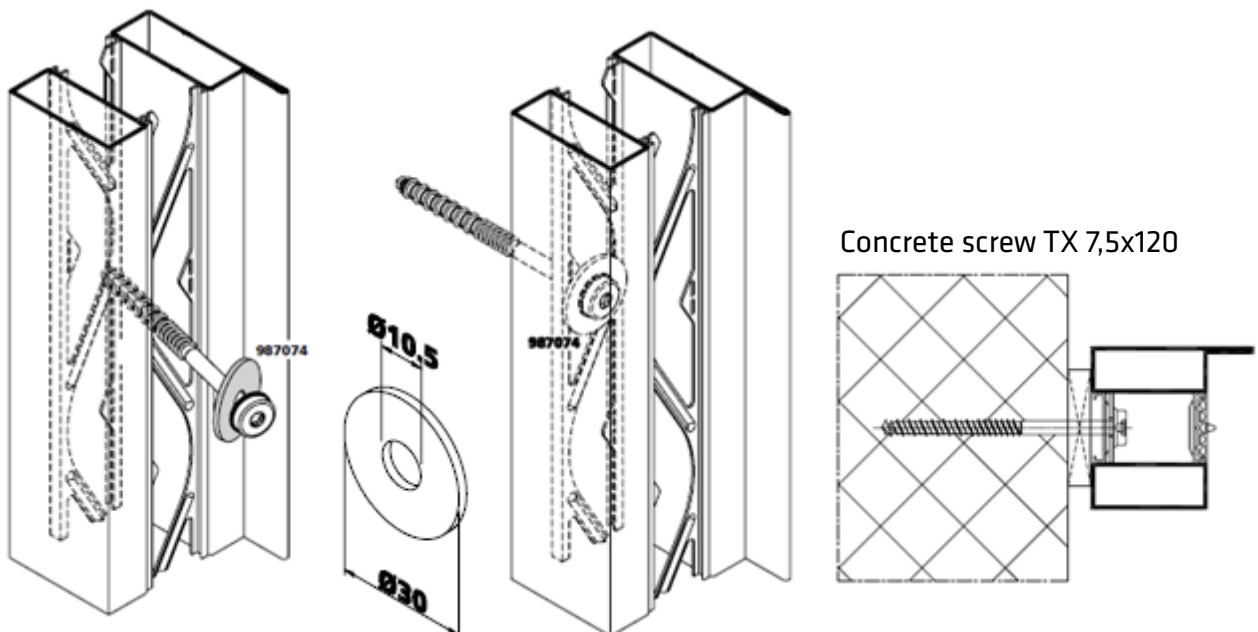



Diagram 2. K-3 (Forster profile) Mounting.



Marking: 06J03v6	 DOORDEC <small>TO WELCOME AND PROTECT</small>
Compiler: Jaak Järvpõld	
Approved: Kaider Puniste	
Valid from: 01.04.2024	

- If necessary the threshold is attached to the floor from the prepared mounting hole. Doors without a threshold have additional fixing points to fasten the door frame to the floor. A fire resistant door without a threshold must be manufactured accordingly and may be installed if the floor is made of non-combustible material on both sides of the door leaf for 100 mm and the door gap does not exceed 10 mm. Door without a threshold has an auxiliary part fixed under the frame for transport at the factory, which must be removed before installing the product.
- If the fixing holes in the frame cannot be used for some reason, montage plates must be used. Montage plates must be attached to the frame with four non-corrosive blind rivets or at least Ø 3.2 mm steel self-drilling screws.
- The installation gap between the product and the structure must be filled with materials that are specified in subsection 3 table 2. When filling with wool, the wool must be tightly installed between the side frame and the structure. Installation foam must be used on both sides of the frame in the extent of 20 mm. It is not necessary to fill the gap with installation foam in the extent of the entire width of the frame. It is permitted to leave gaps between two layers of foam. In the case of doors that are installed in external walls, a 5 mm gap must be left under the threshold for foam. For sealing, the joint between the threshold and the floor must be covered with silicone on the outdoor side. When using installation foam, fire-resistant foam must be used for fire grade products. See table 2. In cold weather, the permitted installation temperature of the foam must be observed. If the installation foam is not covered with plaster or some other fire-resistant material, it must be covered with steel trims. The trim must overlap with the wall by at least 5 mm and with the frame by at least 10 mm. The trims are attached to the frame by using blind rivets. The distance between the rivets must be short enough to ensure that the trims are properly fixed. In most cases, rivets should be placed at an interval of 600 mm.

5.2. The order of installation operations

- Remove the door sheet from the frame. Place the door sheet on a wooden or other base in order to avoid scratching it by leaning it on the floor.
- Place the frame in the opening, fixing it in the opening so that the frame is straight and in the required place. Use mounting wedges, if necessary (see point 3.1)
- Start attaching the frame from the attachment point at the upper hinge. Move on to the attachment point at the bottom hinge. Then fasten the upper fixing of the frame on the auxiliary side or the opposite side. Install the door leaf to the frame, check the parallelism of the gaps between the door leaf and the frame on the upper and lower edges of the door leaf, on the lock and hinge side. Make sure that the gaps between the door leaf and the frame are equal and parallel. The permitted gap is 4 ± 2 mm. The permitted stationary tolerance of the frame in the horizontal and vertical directions is ± 2 mm. If necessary, adjust the door, hinges or fastening. Fasten the lower attachment point of the frame on the auxiliary side

Marking: 06J03v6	 TO WELCOME AND PROTECT
Compiler: Jaak Järvpõld	
Approved: Kaider Puniste	
Valid from: 01.04.2024	

or opposite. Double check the door slots and movement. Then fasten the frame firmly at all points of attachment.

- Fill/seal the installation gap based on the instructions in Table 2.
- Make sure that the door sheet moves freely and the door closes smoothly. Make sure that the lock can be turned properly on both sides. Make sure that the door closes properly and tongue of the lock remains in a fixed position. If there is a closer, install the closer on the frame and the arm of the closer to the door sheet based on the installation instructions of the manufacturer of the closer. Warning! In the event of a closer with a link arm, the arm of the closer must remain approximately at a 90° angle with respect to the door sheet when the door is closed. Make sure that the closer is functioning. If necessary, adjust based on the instructions of the manufacturer of the closer.
- Install the trim or finish the sides of the door opening.

5.3. Installing glass

- Before installing glass make sure that the door and glass are in good condition and clean.
- When installing the slats it must be ensured that the slats are installed back in the same locations as it was before.
- When installing the glass, make sure that there is both an outer and an inner glass seal. (Depending on the type of door/window, seals suitable for indoor or outdoor conditions are included.)
- The glass is installed on blocks, which are placed on the profile at a distance of ~100mm from the edge of the glass. The glazing gap between the profile and glass is 7.5 mm.
- Horizontal slats must be installed first, then vertical slats. To fasten the slats, hit them with a rubber hammer in the direction of the arrow indicated by the letter "A" above the glass slat screw (diagram 4). If necessary secure the fixing by hitting the glass slat in the direction of the screw axis. Start the fastening of the slat from one end and continue towards the other end. Make sure that there is no gap between the slat and the profile.

Diagram 4 installing glass

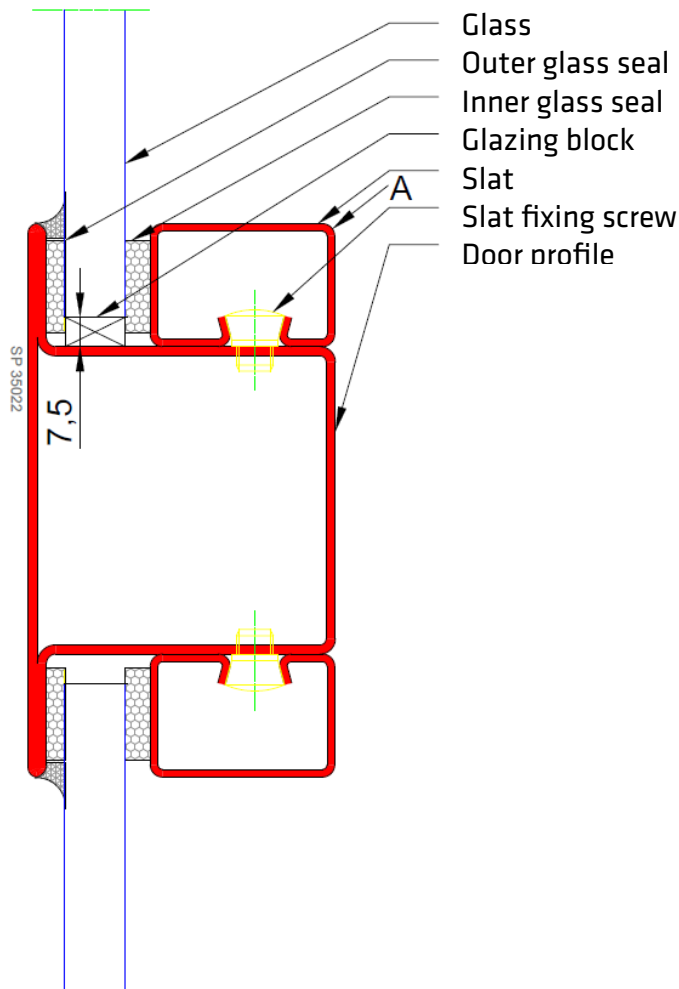

In case of any differences between the instructions and the actual situation on the installation site, as well as in the case of any issues or questions, please contact a representative of Doordec OÜ before installation (the contact information can be found in the header of the instructions).